

PATROL® - 108PET

WEATHERPROOF
CURTAIN PIR & MW
DETECTOR FOR
INDOOR/OUTDOOR USE

«AUTOMATIC HEATING OF
PYROELECTRIC SENSOR»



GSN Electronic Company Ltd.

1

PATROL-108PET Combined PIR & MW detector designed for use indoor or outdoor areas and low-temperature environments up to - 40°C.

PATROL-108PET creates a narrow protective curtain allowing free movement within the protected area without triggering the alarm.

PATROL-108PET with anti-mask technology, detect all types of masking attempts.

PATROL-108PET provides pet immune detection up to 30kg.

2

FEATURES

- DUAL TECHNOLOGY PIR & MW
- IMMUNE TO PETS UP TO 30KG
- ANTI-MASK PROTECTION
- LOW-TEMPERATURE ENVIRONMENTS UP TO - 40°C.
- AUTOMATIC HEATING OF PYROELECTRIC SENSOR
- SHOCK SENSOR (option)
- DOPPLER PULSE-COUNT SELECTION (1-5)
- INDIVIDUAL PIR & MW SENSITIVITY ADJUSTMENT
- AUTOMATIC TEMPERATURE COMPENSATION
- VISIBLE LIGHT DISTURBANCE PROTECTION
- DOUBLE RFI/EMI PROTECTION
- WEATHERPROOF HOUSING

3

DETECTOR INSTALLATION MANUAL

1. Run the installation wire through the bracket-wiring hole.
2. Mount bracket onto the wall and affix with screws, using the knockouts.

Corner installation Wall installation

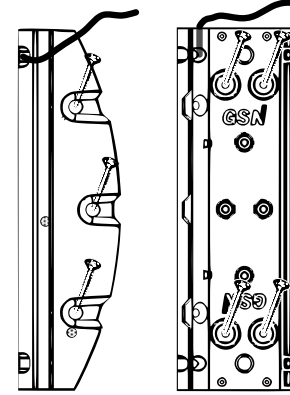

4

3. Run the installation wire through detector back cover.
4. Mount back cover of the detector to the bracket using four screws.
5. Insert the PCB and connect wires according to the schematic.
6. Close front cover and affix with screw.

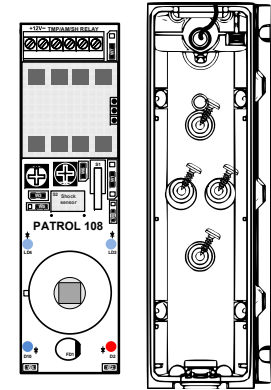

5

TERMINAL BLOCK CONNECTION

+12V - TMP/AM/SH RELAY

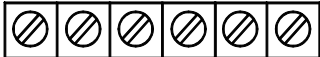

Terminals “+12V-“ – for connection to the power supply of the control unit.

Terminals “TMP/AM/SH/” – for connection to a 24-hour normally closed protective zone in the control unit.

TMP – Tamper
AM – Anti-mask
SH – Shock Sensor

Terminals “Relay” – PIR detector relay output.

6

PATROL-108PET MOUNTING OPTIONS

Detector can be installed vertically (see illustration). Recommended installation height is 2.5m.

* For installation over 2.5m, mount the detector at an angle of 20 degrees.

NOTE! Avoid installing detector where direct sunlight can permeate in pyro sensor.

7

DETECTION AREA

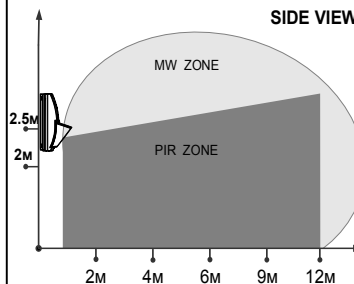
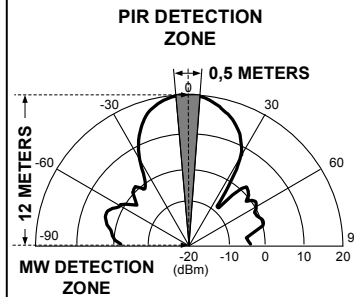

8

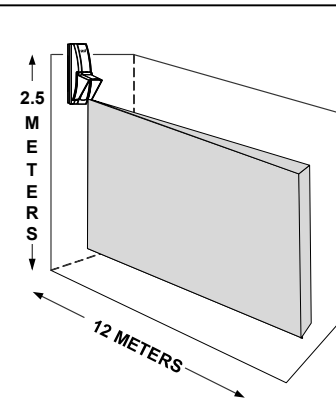

Wall Installation

9

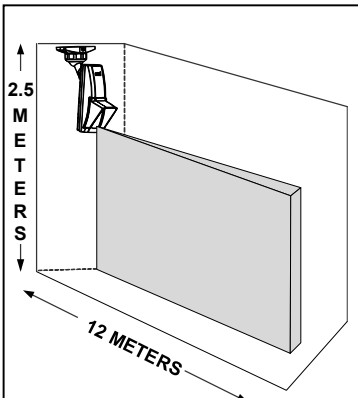

Ceiling Installation with using the bracket: **UBL-1117**.

10

W1 OPERATING AND TEST MODES SETTING



W2 ON/OFF LED JUMPER



W3 PULSE PROGRAMMING JUMPER



W4 JUMPER TO SELECT NC/NO (change of switching relay modes)



W5 ON/OFF SHOCK SENSOR JUMPER (OPTION)



11

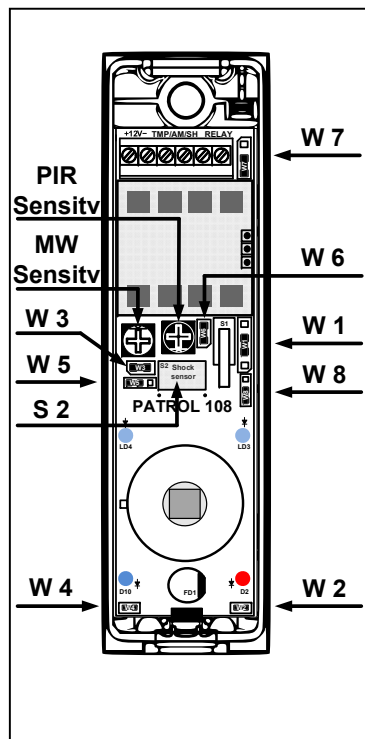

12

W6 ANIMAL WEIGHT JUMPER



W7 ON/OFF ANTI-MASKING JUMPER



W8 ON/OFF HEATING OF PYROELECTRIC SENSOR JUMPER



PIR SENSITIVITY PIR SENSITIVITY ADJUSTMENT



MW SENSITIVITY MW SENSITIVITY ADJUSTMENT



13

PIR ADJUSTMENT

1. Remove the front cover.
2. Connect the power and wait for LED to stop flashing (warm-up time 50 sec).
3. Set Jumper W1 to the "PIR TEST" position, contacts RELAY is open.
4. Replace the cover.
5. Use the "PIR SENSITIVITY" potentiometer to adjust the PIR sensitivity, moving within the protected area. The red LED should flash with step.

MW ADJUSTMENT

1. Remove the front cover.
2. Set Jumper W1 to the "MW TEST" position, contacts RELAY is open.

14

3. Replace the cover.

4. Use the "MW SENSITIVITY" potentiometer to adjust the MW sensitivity, moving within the protected area. The blue LED should flash with each step.

OPERATION MODE OF ANTI-MASKING SYSTEM

1. Set Jumper W1 to "WORK" position.
2. Set Jumper W6 according to animal weight.
3. Close the cover – LED will blink - 15 flashes.

IMPORTANT! For correct setting of the anti-masking system - please go out from the detection zone review until the red indicator won't stop flashing.

4. Affix the cover with screw.

15

SHOCK SENSOR (OPTION)

PATROL-108PET includes a shock sensor that detects external attack. Any physical impact or attempt to separate the detector from the wall will trigger an alarm signal to the control panel through the terminal «TMP/AM/SH».

Jumper W5 enables/disables the shock sensor.

Jumper W5 On - Shock Sensor activated.

Jumper W5 OFF - Shock Sensor disabled.

16

CHANGING RELAY SWITCH CONNECTIONS

1. Disconnect the power.
2. Set Jumper W4 to "NO" position.
3. Restore power.

PULSE-COUNTING METHOD

Selectable pulse count 1, 2, 3, 4, 5 provides users with the option of optimizing detector sensitivity to suit the environment, thus retaining reliable performance at all times. To adjust pulse count for specific operating environments:

1. Remove Jumper W3. The blue LED blinks indicating that pulse counting has begun.
2. Return Jumper W3 during pause between LED blinking.

17

TECHNICAL SPECIFICATIONS

Input voltage.....	9 – 16V
Current consumption:	
In standby mode:	47mA
In alarm mode:.....	72mA
Microwave frequency:.....	24.125GHz
Anti-mask startup (boot) period:.....	50 ± 5sec
Warm up period:.....	50 ± 5sec
Detection range:.....	12m
Detection speed range:.....	0.2 – 4m/sec
Relay output:.....NC/NO; 60V; 100mA; 16Ω
Relay output: TM/AM/SH/.....NC; 60V; 100mA; 16Ω
Anti-mask alarm activation delay:.....	40-60sec

18

Adjustable mask detection:.....	0 –12cm
Alarm period:.....	3sec
Reset time:.....	5±1sec
Pulse counter:.....	1–5
Installation height:.....	2.5m
Light immunity:.....	no less than 50000 lux
Operating temperature range:.....	- 40°C +60°C
Storage temperature range:.....	- 60°C +80°C
Protection rating.....	IP65
RFI immunity: 30V/m at a frequency range 30MHz-2GHz	
EMI immunity.....	50,000V
Dimensions:.....30mm x 25mm x 111mm
Weight:.....	85gr.

19

WARRANTY:

G.S.N. Electronic Company Ltd. warrants this product to be free from defects in materials and workmanship under normal use and service for a period of five year from the last day of the week and year whose numbers are printed on the printed circuit board inside this product. GSN obligation is limited to repairing or replacing this product, at its option, free of charge for materials or labor, if it is proved to be defective in materials or workmanship under normal use and service. GSN shall have no obligation under this Limited Warranty or otherwise if the product is altered or improperly repaired or serviced by anyone other than GSN. GSN shall not be liable for any malfunction that may be caused due to improper installation. The customer should take all precaution necessary to avoid and eliminate electro-static discharges and/or any other disturbances that might interfere with its operation of the product. There are no warranties, expressed or implied, of merchantability or fitness for a particular purpose or otherwise, which extend beyond the description on the face hereof. In no case shall GSN be liable to anyone for any consequential or incidental damages for breach of this or any other warranty, expressed or implied, or upon any other basis of liability whatsoever, even if the loss or damage is caused by GSN own negligence or fault. GSN does not represent that this product can not be compromised or circumvented; that this product will prevent any person injury or property loss or damage by burglary, robbery, fire or otherwise; or that this product will in all cases provide adequate warning or protection. Purchaser understands that a properly installed and maintained product can only reduce the risk of burglary, robbery or other events occurring without providing an alarm, but it is not insurance or a guarantee that such will not occur or that there will be no personal injury or property loss or damage as a result. Consequently, GSN shall have no liability for any personal injury, property damage or any other loss based on claim that this product failed to give any warning. However, if GSN is held liable, whether directly or indirectly, for any loss or damage arising under this limited warranty or otherwise, regardless of cause or origin, GSN maximum liability shall not in any case exceed the purchase price of this product, which shall be the complete and exclusive remedy against.

20