

TR6100

Conventional Reflective Beam Detector Installation and Operation Manual

[Everday Technology Co., Ltd.](#)

No.95, Sec.2, Ligong 1st Rd., Letzer Industrial Park, Yilan County 26841, Taiwan

Tel: 886-3-990-6099 Fax: 886-3-990-6029

www.everday.com



Product Safety

To prevent severe injury and loss of life or property, read the instruction carefully before installing the beam detector to ensure proper and safe operation of the system.



European Union directive

2012/19/EU (WEEE directive): Products marked with this symbol cannot be disposed of as unsorted municipal waste in the European Union. For proper recycling, return this product to your local supplier upon the purchase of equivalent new equipment, or dispose of it at designated collection points.



For more information please visit the website at www.recyclethis.info

EN54 Part 12 Compliance

TR6100 Conventional Reflective Beam Detector complies with the requirements of EN54-12: 2002.



Table of Content

1 Introduction.....	4
1.1 Overview	4
1.2 Feature and Benefits	4
1.3 Technical Specification	5
1.4 Product Appearance	6
1.5 Principle of the Beam Detector	6
2 Installation Procedures.....	7
2.1 Mounting Details	7
2.2 LED Indicators LED	7
2.3 Mounting Preparation.....	8
2.4 Mounting of the Beam Detector	8
2.5 Mounting of the Reflective Mirror	9
2.6 Cabling Details.....	10
3 Programming Sensitivity and Span	10
3.1 To View the Detector Parameter	10
3.2 To adjust the Sensitivity	11
3.3 To adjust the Span (Distance)	11
4 Commissioning Beam Detector	12
4.1 Commissioning Preparation.....	13
4.2 Step 1: Entering Commissioning Method	13
4.3 Step 2: Sightline Alignment Procedure	13
4.4 Step 3: Acceptable Adjustment Procedure.....	13
4.5 Step 4: Finalizing Installation.....	13
4.6 Step 5: Testing Fire Signal.....	13
4.7 Step 6: Testing Fault Signal	14
5 Other Function.....	14
6 Maintenance.....	15
7 Troubleshooting Guide.....	15
8 Supplied Accessories.....	15
9 Appendix 1	16
9.1 Limitation of Beam Detectors	16

1 Introduction

1.1 Overview

TR6100 Conventional Reflective Beam Detector has built in Laser beam pointing and Digital guide display for real user friendly alignment method. The Laser beam pointing accurately point the exact location where to mount mirror and with additional digital guide display allows to monitor and guide on the actual light intensity between the mirror and detector which cannot be seen by our naked eye making it more easy and convenient in alignment commissioning.

The TR6100 has four adjustable operational ranges of between 8 to 20, 20 to 40, 40 to 70 and 70 to 100 meters beside with three adjustable sensitivity setting ranges from 2.6dB, 3.8dB and 5.8dB to meet the specific environmental requirement. The TR6100 works on the principle of reflective infrared beam obscuration. Used in conjunction with a reflector, it will notify the fire alarm panel when the infrared beam is obscured by smoke.

The TR6100 is ideal for use high ceiling and wide areas such as warehouses, large storages, shopping malls, leisure centres, exhibition halls, hotel lobbies, printing houses, garment factories, museums and prisons, as well as places where slight smoke particles or corrosive gas exist.

1.2 Feature and Benefits

1. EN54-12 Compliance
2. Hassle free alignment, built with digital guide display and laser beam pointing
3. Employ single-ended design through reflective mirror
4. Four ranges wide monitoring from 8-100 meters via encoder
5. Three users programing sensitivity adjustment
6. Built-in microprocessor
7. Self-diagnosis function can monitor for internal faults
8. Automatic compensation for factors weakening received signals, such as dust contamination, positional movement and ageing of the transmitter
9. Fire and Fault interfacing relays
10. Attractive and pleasing appearance
11. Real User friendly alignment method

1.3 Technical Specification

Part Number	TR6100
Standard	
Listed	LPCB Pending
Compliance	EN54-12
Fire Detection and Alarm Systems	BS 5839 Part 1:2002
Specification	
Operating Voltage	20 V to 28 V DC
Current Parameters	Standby: 23mA Commission: 56mA Alarm: 33mA
Beam Sensor Sensitivity [via Encoder]	Level 1: 2.6 dB High Sensitivity Level 2: 3.8 dB Medium Sensitivity Level 3: 5.8 dB Low Sensitivity
Beam Pathway Length [via Encoder]	Span 1: 8 to 20 meters Limited Path Span 2: 20 to 40 meters Short Path Span 3: 40 to 70 meters Normal Path

TR6100 Conventional Reflective Beam Detector Installation & Operation Manual

Beam Path Angle	Span 4: 70 to 100 meters Long Path $\pm 0.5^\circ$ Directional
Alignment Guide	Laser Beam Pointer
Digital Display Guide	Nixie Tube
LED Indicator Guide LED	Red: Fire ; Yellow: Fault ; Green: Alignment
Reset Time	Less than 2 Second
Relay Capacity [Fire & Fault]	Normally Open & Close/ 2.0 A; 30 VDC

Physical

Material / Colour	ABS / White
Dimension / Weight	L:190.87 x W:126.87 x H:91.96 mm / 440 gm
Weight	0.130 Kg with base

Environmental

Operating Temperature	-10°C to +50°C
Ingress Protection Rating	IP30 [IP66 glue seal-For permanent fixing]
Humidity	0 to 95% Relative Humidity, Non condensing

1.4 Product Appearance



1.5 Principle of the Beam Detector

The TR6100 reflective optical beam smoke detector incorporates a light transmitter and the detector on the same unit. The light path is created by reflecting light emitted from the transmitter off a retro-reflector, meaning it is reflecting light back to its source with a minimum of scattering, which is placed opposite the detector.

In a fire, when smoke falls within the path of the beam detector, some of the light is absorbed or scattered by the smoke particles. This creates a decrease in the received signal, leading to an increase in optical obscuration. This unit decodes or analysts received signals and compare to the pre-programmed algorithm stored on the processor. Through this algorithm the detector will decide

Everday Technology Co., Ltd.

No.95, Sec.2, Ligong 1st Rd., Letzer Industrial Park, Yilan County 26841, Taiwan
Tel: 886-3-990-6099 Fax: 886-3-990-6029

www.everday.com



TR6100 Conventional Reflective Beam Detector
Installation & Operation Manual

whether fire is defined or not and lead to enablement the corresponding relays and LED indicators. The unit on the operating mode maintaining continually emitting light, care should be taken that the activities in the space do not obstruct the beam or move the device to avoid false operation of the detector. Refer to Figure 1.

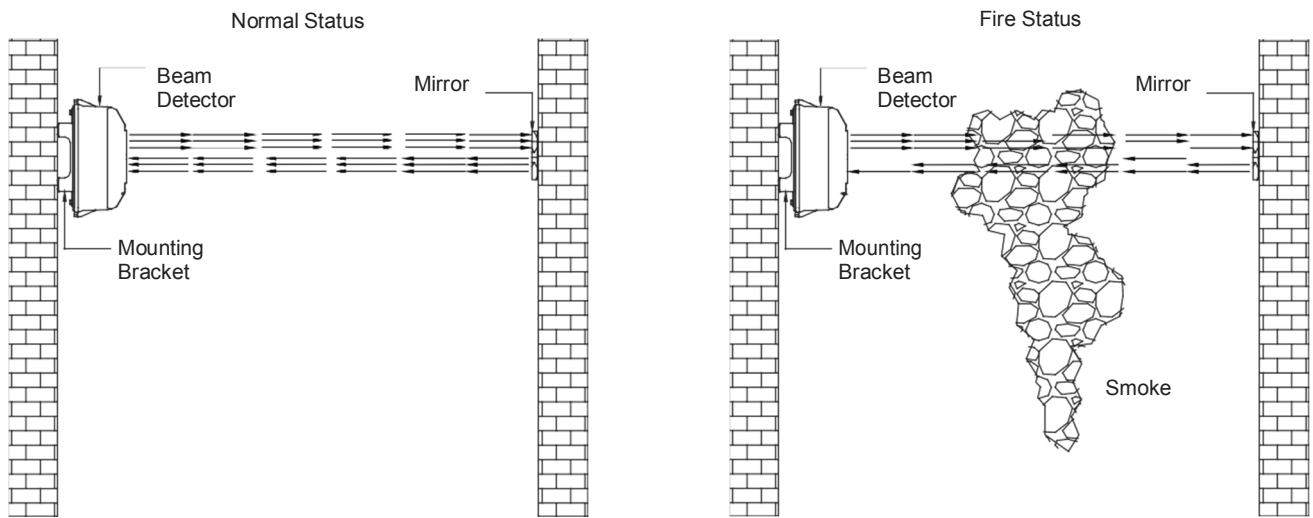

Figure 1: Beam detector principle

2 Installation Procedures

2.1 Mounting Details

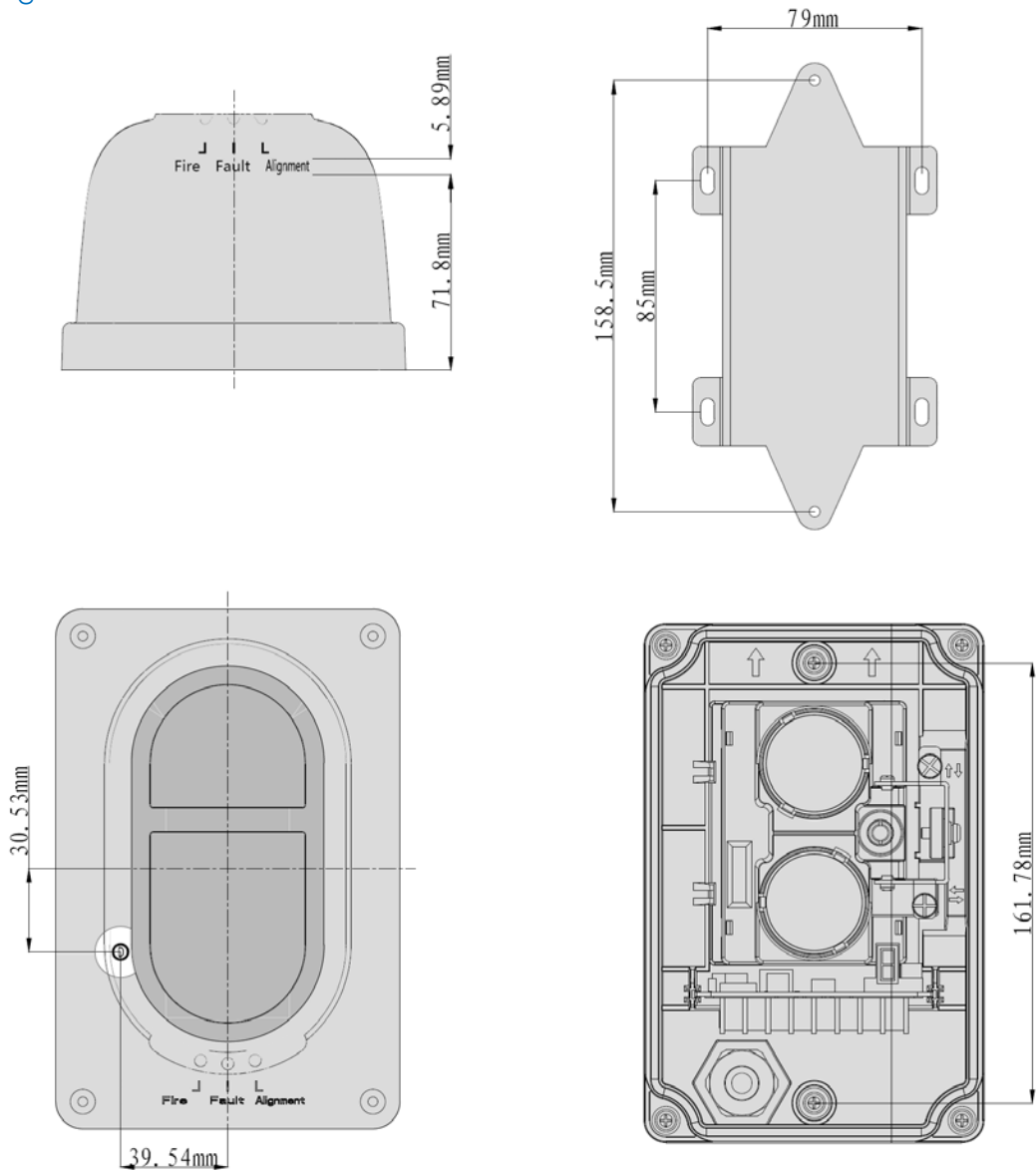

Figure 2: Detector Diagram

2.2 LED Indicators LED

LED Indicators	Colour	Function
Fire	Red	Illuminates when at least one fire alarm event occur
Fault	Yellow	Illuminates when at least one fault alarm event occur in the Detector
Alignment	Green	Illuminates during the commissioning

2.3 Mounting Preparation

This beam detector must be installed, commissioned and maintained by a qualified or factory trained service personnel. The installation must be installed in compliance with all local codes having a jurisdiction in your area or BS 5839 Part 1 and EN54.

Note: The device component within the device is vulnerable specially the reed switch. It is advisable to use the magnetic tool when needed to prevent physical damage.

1. Under flat spare area. If the ceiling height is less than 8 meters, the beam detector should be installed 0.5 meter to 1 meter below the ceiling level. Refer to Figure 3.
2. Under flat spare area. If the ceiling height is more than 8 meters, the beam detector should be installed minimum of 0.5 meter below the top ceiling. Refer to Figure 3.
3. The chosen for the location should be clean and dry and not subject to shock, vibration or electro-statistic discharge, and free from glass wall, sunlight direction any reflective barrier.
4. Make sure that the beam path is free form obscuration against moving items.

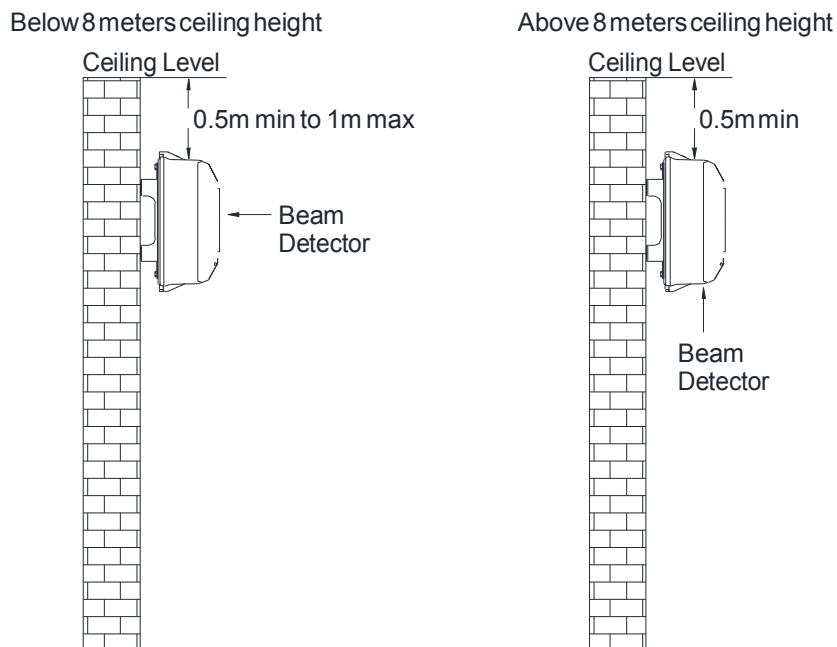

Figure 3: Installation Details

2.4 Mounting of the Beam Detector

1. Using the supplied bracket, mark the position of the fixing holes.
2. Drill four holes and insert an 8mm wall plug into each.
3. Fix the mounting bracket to the wall using four ST4x30 screw. Refer to Figure 4.
4. Fix the detector base onto the bracket using two M4x12x10 standard screws. Refer to Figure 5.

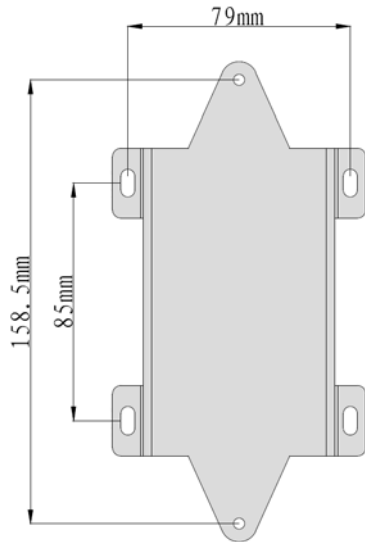

Figure 4: Mounting Bracket

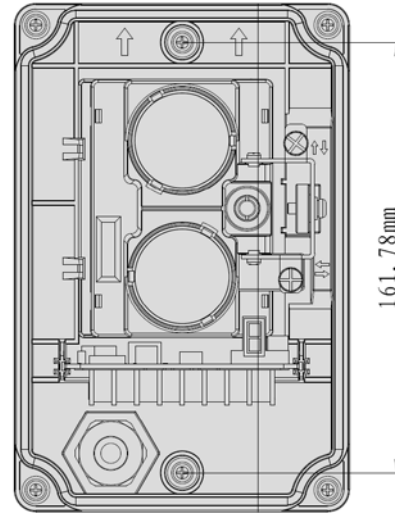

Figure 5: Beam Detector

2.5 Mounting of the Reflective Mirror

1. Depending on the project requirement, if the distance between the detector and the reflector mirror is 8m-40m, install one reflector is enough; if the distance is 40m-100m, four reflectors is required. Refer to Figure 6.
2. Mark the position of the fixing holes plastic expansion bolts.
3. Fix the reflector mirror using two ST4x30 standard screws, in the case of one-unit mirror, do the same steps for other mirrors if required. Refer to Figure 6.

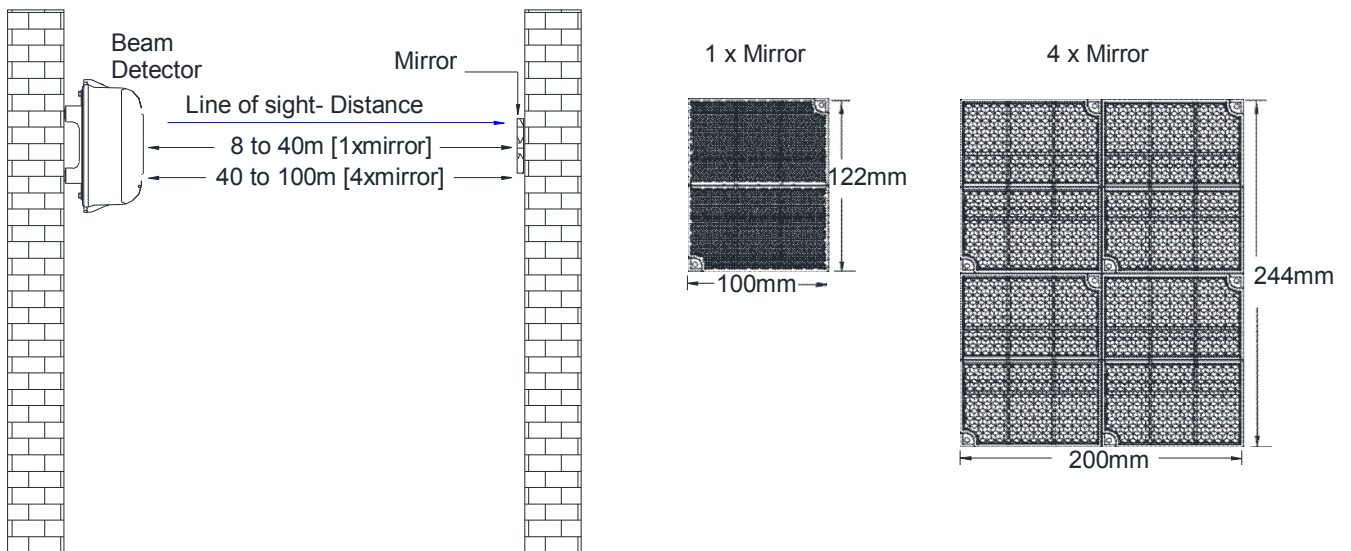

Figure 6: Mounting of Reflector Mirror

2.6 Cabling Details

Cables should be brought into the detector using the supplied glad cable. The maximum size of the cable which can be terminated is 1.5mm². Observe the polarity. Refer to Figure 7.

1. Terminal D1 (+) and D2 (-) for connecting Power supply [24VDC]
2. Terminal S1 and S2 for connecting handheld programmer
3. Terminal HJ1 and HJ2 for connecting Fire signal relay output [Normally Open]
4. Terminal GZ1 and GZ2 for connecting Fault signal relay output [Normally Close]



Figure 7: Wiring Terminals

3 Programming Sensitivity and Span

The TR6100 sensitivity and the operation range can be adjusted through hand held programmer on project site. The programmer can be purchased separately. It is mandatory for the commissioning personnel have programmer tool in order to adjust the detector according to the site situation and environmental requirement. Refer to Figure 8.

Warning: Disconnect the power and loop connection whilst connecting to the handheld programmer.

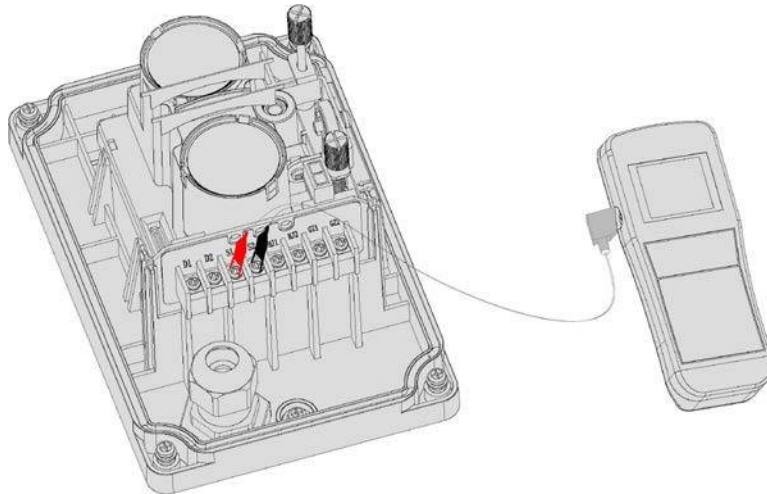

Figure 8: Programming connection Details

3.1 To View the Detector Parameter.

1. Connect the programming cable to S1 and S2 terminals. Polarity is not required and detector must be powered off.
2. Switch on the programmer, then press button "1" to view the address code and sensitivity level.
3. Press button "Page" to view the Span parameter.
4. Press again the "Page" to return to the previous parameter.

5. Press button "**Exit**" to clear and exit. (Figure 9)



Figure 9

3.2 To adjust the Sensitivity

1. Connect the programming cable to S1 and S2 terminal. Polarity is not required and detector must be powered off.
Reference: (Figure10)
2. Switch on the programmer, then press button "**3**" then display "**Sensitivity and Span(m)**".
3. Then enter the desire sensitivity value from 1, 2, or 3 by pressing "**Clear**" key and then input the value and then press "**Write**" key , then will highlight the previous Span value, it means the entered sensitivity is confirmed. If display "**Fail**", it means failure to program the sensitivity.

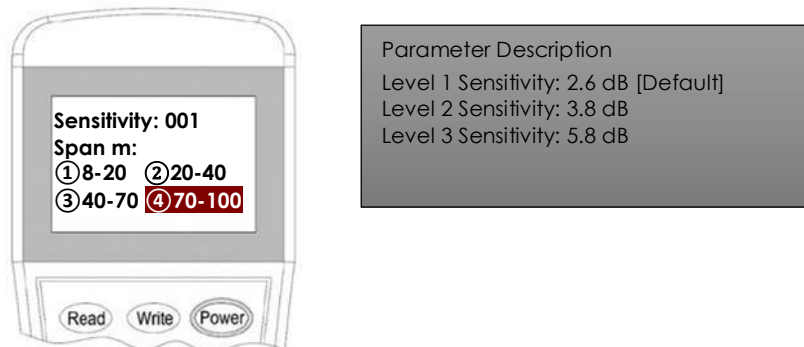
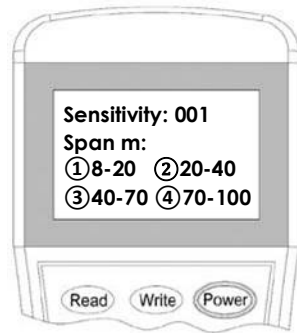

Figure 10

3.3 To adjust the Span (Distance)

1. Connect the programming cable to S1 and S2 terminal. Polarity is not required and detector must be powered off.
2. Switch on the programmer, then press button "**3**" then display "**Sensitivity and Span (m)**". Then enter then press "**0/Page**" key to highlight the previous Span setting. Then press value from 1, 2, 3 or 4 correspond to the span value and then press "**Write**" key. (Figure 11)

Note: If display "**Success**", means the entered span is confirmed. If display "**Fail**", means failure to program the span.



Parameter Description

Span 1: 8 to 20 meter [Limited Path]
Span 2: 20 to 40 meter [Short Path]
Span 3: 40 to 70 meter [Normal Path-Default]
Span 4: 70 to 100 meter [Long Path]

Figure 11

4 Commissioning Beam Detector

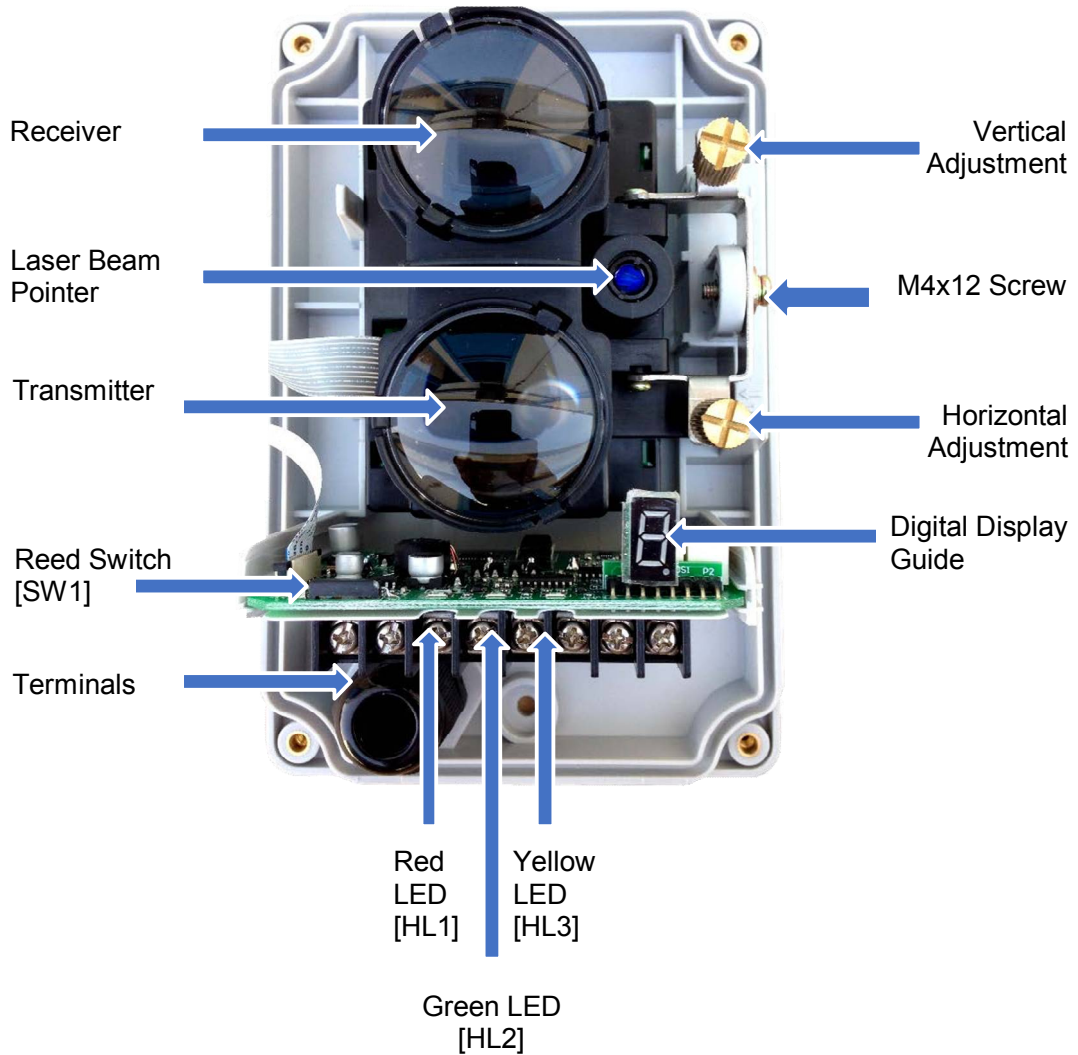

Figure 12: Names and Location

4.1 Commissioning Preparation

1. Make sure both beam detector and reflective mirror are properly and securely mounted.
2. Make sure that the line of sight is clear and both beam detector and reflective mirror are in placed with accurate axis angle.
3. Make sure that the suitable numbers of reflective mirror are installed depending on the distance between detector and mirror.
4. Make sure require Span setting is adjusted through handheld programmer depending on the distance between the detector and mirror. [Span1:8-20meters; Span2:20-40meters, Span3:40-70meters, Span4:70-100meters].
5. Wiring should be done correctly.

4.2 Step 1: Entering Commissioning Method

- a. Remove the detector cover and power on the device.
- b. Place the supplied magnetic tool alongside the Reed Switch [SW1]. After a while the Green LED [HL2] should turn on steady or blinking, and then take out the magnetic tool to start the detector auto alignment process.
Note: Keep the line of sight clear between the detector and mirror. Do not disturb the detector auto alignment process.

4.3 Step 2: Sightline Alignment Procedure

- a. The Laser Beam Pointer should turn on automatically. Look through on the reflective mirror if the laser beam mark at the centre.
- b. Once you located the mark, loosen the M4x12 screw and adjust the horizontal or vertical adjustment wheel until the Laser beam mark at the centre of the mirror. Refer to figure 8.
Note: During the adjustment period the digital display guide indicates number- it is not indicating the signal intensity. If the number is turn to zero [0] it means the Sightline Adjustment is not appropriate and more adjustment is required.

4.4 Step 3: Acceptable Adjustment Procedure

- a. Adjust the signal intensity through the horizontal or vertical adjustment wheel while the detector monitor signal intensity through digital display guide, the number is indicating the signal intensity from 1 to 8. Try to reach number eight [8] to have acceptable adjustment. However, for long path span number 2 or 3 is acceptable adjustment. Make sure that the line of sight is clear between the detector and mirror.
Note: If the number display nine [9] it means the setting of the Span is not appropriate. Power off the detector and re-programmed the appropriate distance between the detector and mirror through programmer.
- b. If Green LED [HL2] steady on, it means that the signal intensity is acceptable.
- c. Tighten M4x12 Screw, and then ready to proceed to the next step.

4.5 Step 4: Finalizing Installation

- a. Insert the detector cover and screw the 4 sides of the detector.
- b. Place the magnetic tool alongside the "(D)" marked.
- c. Right after the Green LED [HL2] is turn-off, take out the magnetic tool to allow the
- d. detector exit in commissioning mode and turn to monitoring mode.
Warning: Do not obstruct or interrupt the signal between the detector and mirror.
Note: The Yellow LED [Fault] and Green LED [Alignment] will begin blinking simultaneously for about 3 seconds then Red LED [Fire] will begin blinking every 3 seconds, indicating that



the beam detector is commissioned.

Keep the detector run for at least 20 seconds then proceed to the next step.

4.6 Step 5: Testing Fire Signal

- a. Using supplied Opaque/Translucent materials, cover-on half of the beam detector using the translucent portion of the material. With less than 30 seconds the Red LED [Fire] will turn on steady, indicating Fire signal. [The fire alarm relay [HJ1 and HJ2 will latch to normally close]. Refer to Figure 9.
- b. Remove the testing material and cut the power off for at least 2 seconds to reset the detector.

4.7 Step 6: Testing Fault Signal

- a. Using supplied Opaque/Translucent materials, cover-on the half of the beam using the opaque portion of the material. Right after the Yellow LED [Fault] turn on, indicating the fault signal. [The fault alarm relay GZ1 and GZ2] will latch to normally close]. Refer to Figure 13.

Note:

1. If the opaque material is taken out from the detector in less than 15 seconds, then the detector automatically reset to normal status.
2. If the opaque material is not taken out from the detector and is maintained for more than 15 seconds then a fire signal is registered, turn-off the power for at least 2 seconds to reset the detector.

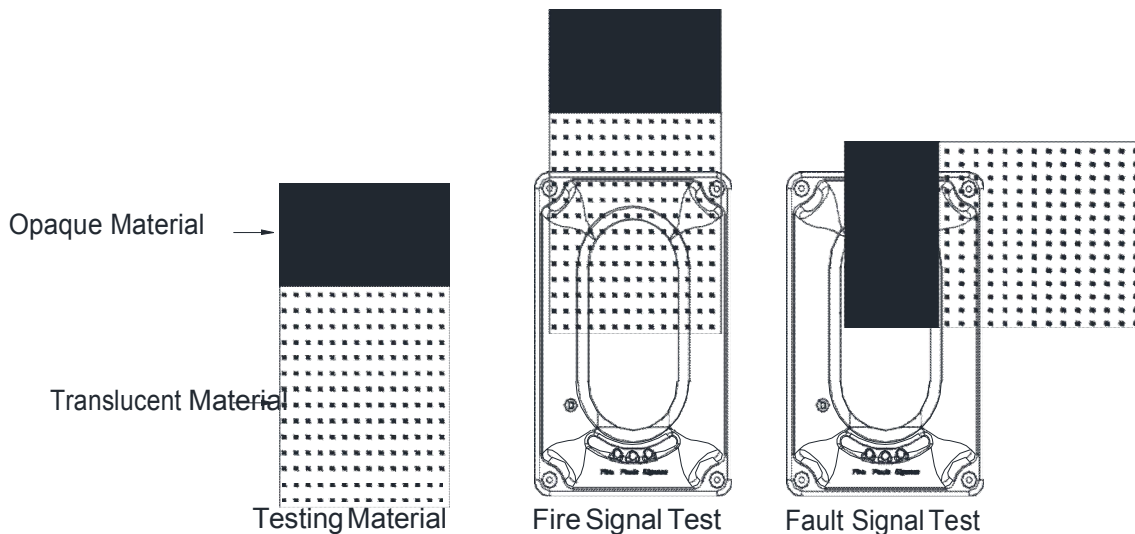

Figure 13: Testing Details

5 Other Function

Automatic Compensation of Light

When dust exists in the working environment of the detector, the emitting window, receiving window and reflector will be covered with dust, which will affect normal operation. In order to solve the problem, we designed the function of automatic compensation of light. When there is dust on windows, the detector can judge the amount of dust, and compensate the received signal through internal program and circuit to ensure the detector can continue to work normally. The detector gives

fault signal when dust on the lens and reflector surface reaches a certain level and light compensation reaches the limit for the detector to work normally.

Self-diagnosis on Optical Signal

The detector has functions of checking emitting, receiving and amplifying circuit. When there is fault with these three parts of circuit during operation, the detector will generate fault information.

6 Maintenance

1. Inform the suitable personnel before conducting the maintenance.
2. Disable the detector on the control panel to prevent false alarm.
3. Do not attempt to adjust or modify the detector, it may affect the ability of the detector to respond to a fire condition and will void the manufacturer's warranty.
4. Use a damp cloth to clean the detector. Do not use cleaning chemicals that may leave residue on the electronic parts and smoke sensor.
5. Notify again proper personnel after conducting the maintenance and make sure to enable the detector and confirm if up and running.
6. Perform the maintenance on semi-annually or quarterly depending on the site conditions.

7 Troubleshooting Guide

Trouble	Comment	Troubleshooting Advice
Indicates Faults after commissioning	The detector is Dirty The line of sight between detector and mirror was moved Not properly commission at the start	Conduct maintenance Re-Commission the detector
Unable to commission	Transmit/Receive diode is not working The reed switch is damaged	Replace the component
Keep Indicating Fire signal	Check if vibration or electro-statistic discharge is pre-set after commissioned	Re-Commission the detector
Fire signal can't be cleared	There is obscuration on the optical pathway between the detector and the reflector The angle of optical pathway has changed and need to be aligned again	Re-Commission the detector

8 Supplied Accessories

The following accessories are included in the package:

1. Four plastic expansion bolts.
2. Two M4*12*10 three combination cross recessed pan head screws.
3. Four ST4*30 tap cross recessed pan head screws.
4. Mounting Bracket.
5. Opaque/Translucent Material.
6. Six Ø4 flat washers.
7. Magnetic Tool.



9 Appendix 1

9.1 Limitation of Beam Detectors

The beam detector is designed for triggering and initiating emergency fire equipment's; however it only functions when matching with other equipment's. Installation of this beam detector must conform to electrical codes and country standards.

All kinds of smoke detector have restrictions, since fire develops in various ways and are often unpredictable in their progression, it is unforeseeable which type of detector will provide the earliest warning. No types of beam detector can sense every form of fire all the time. Generally speaking, detectors may not warn you about fire caused by insufficient safety measures, violent explosions, leaking gas, improper storage of flammable materials like diluents and other safety hazards, arson or children playing with fire. The alarm of a smoke detector used in high velocity environment will be delayed due to dilution of smoke by frequent and fast airflow. What's more, the beam detector has to be frequently maintained for it is exposed to more dust contamination.

The beam detector cannot last forever. In order to keep the detector working in good condition, please maintain the equipment continuously according to recommendations from manufacturers and relative nation codes and laws. Take specific maintenance measures on the basis of different environments.

Beam detector contains electronic parts. Even though it is made to last for a long period of time, any of these parts could fail at any time. Therefore, test your beam detector at least every half-year according to national codes or laws. Any smoke detectors, fire alarm devices or any other components of the system must be repaired and/or replaced immediately as they fail.

ISSUE NO. MSD20160908 REV. 1.0